



Voltright™

The Sollatek AVR Range

Automatic Voltage Regulators



Single Phase

Three Phase



Voltright™

The Sollatek AVR Range

Automatic Voltage Regulators



WHEREVER mains supply is erratic and unreliable, Sollatek - a world leader in the field of voltage regulation and protection, has the ideal solution to protect all your domestic, commercial and industrial installations.

From small domestic (250 watt) to large industrial 500kVA applications, single and three phase applications, the Sollatek range of voltage regulators is your solution in the most erratic of power conditions.

Main features and benefits

- Microprocessor controlled - high speed response.
- Solid State reliability - no moving parts.
- Widest input variation (of -30% to +22% as standard).
- 1250 Volts per second correction speed.
- High output correction accuracy (of +/-4%) exceeds EC standards.
- Faster and smaller than servo operated units.
- Less expensive to buy and run than servo operated units.
- Quiet, unobtrusive operation.
- Wide input frequency tolerance between 45 to 75 Hz allowing unit to function properly in areas of severe frequency disturbances.
- High overload capability of up to 150% for 4 minutes.
- Very low losses and minimal heat dissipation due to an efficiency of over 96% at full load.
- Warranty of 2 years. Sollatek provides full back up support on all its products, with local support in over twenty countries worldwide.

Contents

Single phase small	Page 4-5
Single phase large	Page 6-7
Three phase indoor	Page 8-9
Three phase outdoor Isolating transformer	Page 10-11
Options	Page 12
Operation principle	Page 13
Technical notes	Page 14-15

General Specifications

Input

Frequency range	45Hz to 75Hz (i.e 50Hz -10%, +50%. or 60Hz -25%, +25%).
Additional voltage THD*	<0.2% at input (tested at 100% linear load), (No PWM methods used).
Maximum input THD*	Can withstand >10% THD from the supply.

Output

Additional voltage THD*	<0.25% at output (tested at 100% linear load), (No PWM methods used).
Crest factor	> 1:3 permissible on load current (tested at 100% load).
Synchronization	Output synchronized to input.
Permissible overload	1000% for 100ms, 150% for 4 minutes, 110% for 10 minutes.
Load types	Designed to run lighting, motors, battery chargers, communications equipment, office equipment, SMPS, air-conditioners, compressors, industrial machines, medical equipment and others. Suitable for all domestic, commercial and industrial sites.

General

Technology	All solid state (static) switching.
Efficiency	>96% (at 100% linear load).
Control	Microcontroller based control system provides self checks, system integrity monitoring and diagnostic indicators.
Control protection	Internal surge arrestors and filters in control circuit protect against disturbances. Filtering algorithms and fault tolerant software protect against disturbances and false measurements.
Ambient temperature range	0 to +55°C.
Relative humidity	>95%, non condensing.
Acoustic noise	< 45 dB (A).
Expected service life	> 25 years.
Standards	Manufactured to comply with :- ISO9001:2000, CE, EN 50081-1:1992, EN 50082-1:1998, EN 55022:1998, EN 61000-4-2:1995/1998, EN 61000-4-3:1996, EN 61000-4-4:1995, EN 61000-4-5:1995, EN 61000-4-6:1996, EN 61000-4-11:1994, DD ENV 50204, BS EN 61558-1, EN 60065, EN 60555.
Input range	-30% to +22%
Output accuracy	± 4%
Correction speed	1250 Volts per sec.
Response	Within 15 millisecond .
kVA rating	The Sollatek AVR range is wide and covers units from as small as 250VA up to 100kVA in single phase and 10kVA to 500kVA in three phase. To choose the correct size from the Sollatek range, refer to the kVA calculator at the back.
Efficiency	88% at 25% load 94% at 50% load 96% at 75% load 97% at 100% load
Power factors	Unaffected by load power factor.

*Total harmonic distortion

Comparison Chart

	Sollatek AVR range	Sollatek SVS range	Other relay based Stabilisers	Servo/mechanical Stabilisers	Benefits of Sollatek AVR
Microprocessor controlled	Yes	Yes	No/some	No	Reliable. Accurate operation allows advanced functions.
Relays	No	Yes (uses zero voltage switching)	Yes	No	Faster correction than mechanical types. Quiet. Low in cost.
Mechanical elements	No	No	No	Yes - uses motorised variable transformer to adjust output	No mechanical elements means no servicing or maintenance required. Extremely fast voltage correction speed.
Requires servicing /maintenance	No	No	No	Yes - especially in dusty environment	Low admin cost.
Typical voltage input range	-30% to +22%	-25% to +15%	±15%	±12.5%	The wide range is ideal, and in some cases essential in countries with chronic mains supply problems.
Typical voltage output range	± 4%	± 6%	± 6%	±1%	± 4% exceeds most international standards.
Cost comparison (rated 1 to 4)*	3	2	4	4 (most expensive if same input range compared ie ± 25%)	Value for money.

* 4 = most expensive

AVR - 250VA to 2500VA

Main Features and Specifications

Introduction

Suitable for all applications for domestic and small office use, this range of AVRs is built into an attractive and modern enclosure to suit and blend with modern equipment.

Sollatek AVRs from 250VA up to 1600VA are built into a plastic enclosure (see table opposite for dimensions). The larger units are built into a metal enclosure with a plastic facia, again providing a smart unit that will blend well with other equipment.

Features

LED display - A seventeen Light Emitting Diodes (LED) display is built on the front panel. This display provides the following indications:

Input Voltage - 7 LEDs indicate the state of the incoming voltage. At a glance it is possible to see the level of under-voltage or over-voltage.

Output Voltage - 5 LEDs indicate the state of the output voltage. A zero % indication shows the output voltage reaching your equipment is at the correct nominal voltage.

Load Current - 5 LEDs display the percentage of rated current the load is drawing through the AVR. Although the Sollatek AVR will withstand 110% overload for long durations, it is never recommended to overload any equipment. The overload indication makes it possible to reduce the load, allowing the AVR to work safely. If the overload persists then the Sollatek AVR will disconnect the load for protection.

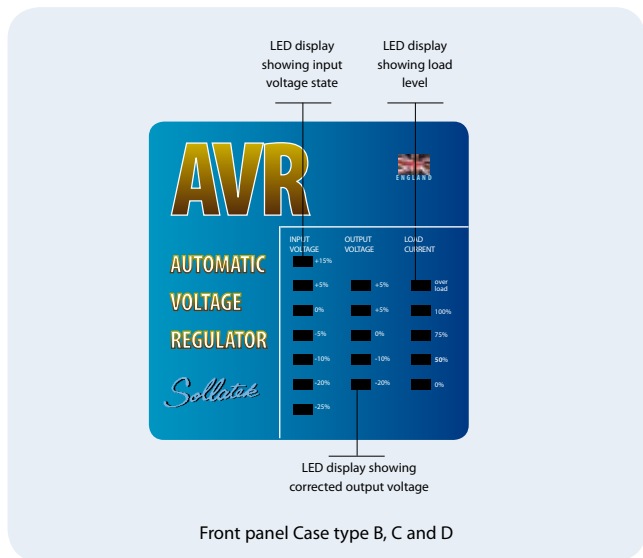
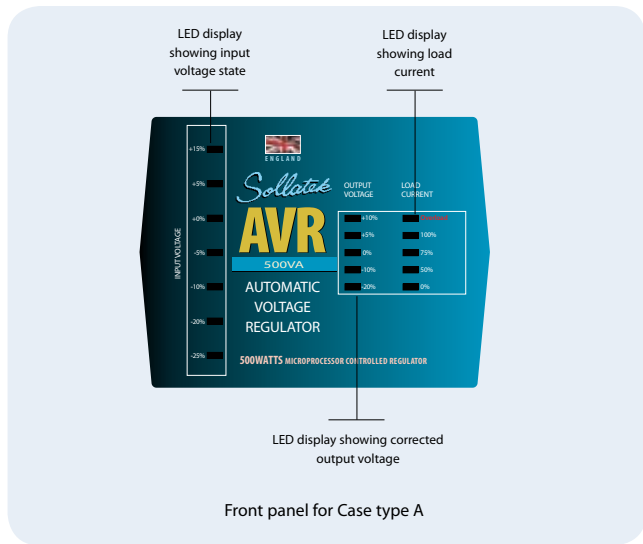



REAR PANELS

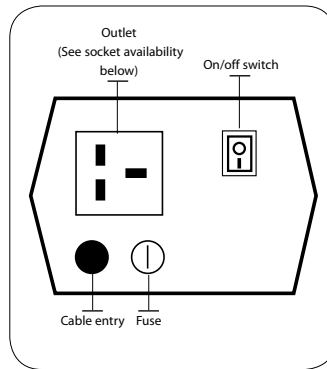

Rear panel Case type A and B

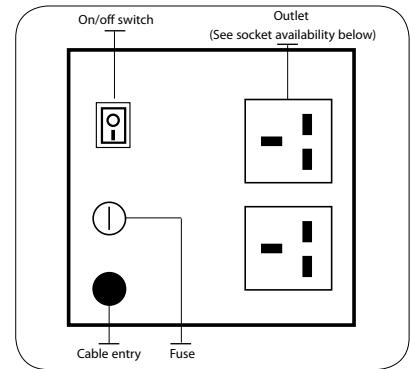

Rear panel Case type C and D

SOCKET AVAILABILITY

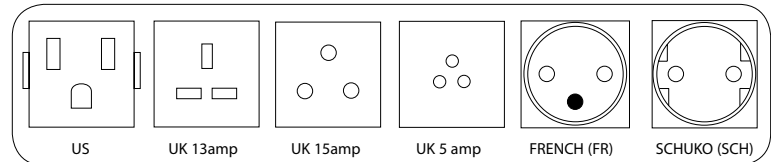

All the above sockets types can be ordered on the rear panels

SPECIFICATIONS

Model	Amps	Voltage	VA	Socket	Weight	Dims	Case Type
AVR01-22	1	230	230	UK,FR,SCH,UK5	4	193 x 100 x 124	A Plastic (ABS)
AVR02-22	2	230	460	UK,FR,SCH,UK5	5	193 x 100 x 124	A Plastic (ABS)
AVR05-22	5	230	1150	UK,FR,SCH,UK15	11	277 x 133 x 161	B Plastic (ABS)
AVR10-22	10	230	2300	UK,FR,SCH,UK15	14	336 x 212 x 179	D Metal
AVR02-11	2	110	220	US	3	193 x 100 x 124	A Plastic (ABS)
AVR04-11	4	110	440	US	4	193 x 100 x 124	A Plastic (ABS)
AVR05-11	5	110	550	US	5	193 x 100 x 124	A Plastic (ABS)
AVR10-11	10	110	1100	US	11	277 x 133 x 161	B Plastic (ABS)
AVR20-11	20	110	2200	US	14	336 x 212 x 179	D Metal

AVR - 5kVA to 100kVA

Main Features and Specifications

Introduction

Suitable for large applications covering a small office to an entire apartment or house, or even a small workshop.

Available from 5kVA (21 Amps at 230V supply) up to 100kVA (260 Amps at 230V) and built into a tower metal enclosure with a small footprint of 295x210 mm (For models up to 10kVA 230V).

Included as standard, this range of AVRs includes an LCD (liquid crystal display) which provides input voltage, output voltage and output current monitoring. Using state of the art technology the Sollatek AVR displays load current in real time, input voltage and output voltage. (Display toggles between input and output voltage, using a switch).



For AVR models up to 10kVA @ 230V (AVR40-22)

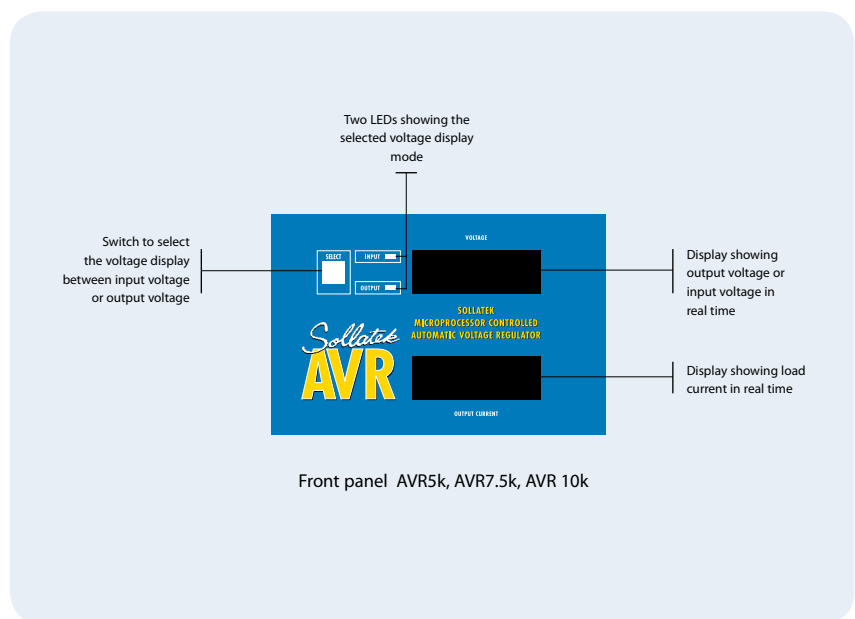



AVR300-22



AVR100-22 with digital display

SPECIFICATIONS

Model	Amps	Voltage	kVA	Weight	Dims
AVR20-22	20	230	4.6	40	235 x 343 x 535
AVR30-22	30	230	6.9	55	235 x 343 x 535
AVR40-22	40	230	9.2	60	235 x 343 x 535
AVR50-22	50	230	11.5	82	460 x 785 x 445
AVR75-22	75	230	17.2	100	460 x 785 x 445
AVR100-22	100	230	23.0	114	460 x 785 x 445
AVR250-22	250	230	57.5	350	680 x 1200 x 1030
AVR300-22	300	230	69.0	382	680 x 1200 x 1030
AVR350-22	350	230	80.5	397	680 x 1200 x 1030
AVR400-22	400	230	92.0	423	680 x 1200 x 1030
AVR30-11	30	110	3.3	36	235 x 343 x 535
AVR40-11	40	110	4.4	40	235 x 343 x 535
AVR50-11	50	110	5.5	50	235 x 343 x 535
AVR75-11	75	110	8.2	56	460 x 785 x 445
AVR100-11	100	110	11.0	65	460 x 785 x 445
AVR250-11	250	110	27.5	127	680 x 1200 x 1030
AVR300-11	300	110	33.0	186	680 x 1200 x 1030
AVR350-11	350	110	38.5	204	680 x 1200 x 1030
AVR400-11	400	110	44.0	287	680 x 1200 x 1030

AVR Three Phase

Main Features and Specifications

Introduction

The three phase AVR is made up from three identical single phase regulator units. Each of these monitors its own output voltage and adjusts for variations in mains supply voltage so as to maintain an output voltage within close limits.

The Sollatek three phase AVRs all feature the same input voltage range as standard of -30% to +22%, making them ideal for all applications where the voltage supply is erratic. Also, when compared to stabilisers of the same input range, the Sollatek AVR is one of the most competitively priced units available.

The Sollatek three phase AVR range is easy to order. All units are rated by the number of AMPS per phase and the input/output voltage. For example:

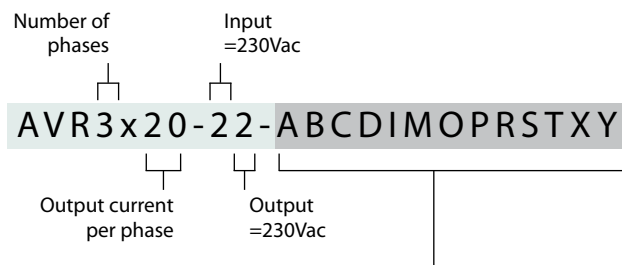

Options:

- A AVS
- B Input circuit breaker
- C Output circuit breaker
- D Surge & lightning protection up to 20kA
- I Isolating transformer
- M Digital meters
- O Outdoor enclosure (IP44)
- P Changeover switch
- R RFI
- S High-level lightning protection >90kA
- T Line reactor
- X RFI + line reactor
- Y Manual bypass switch

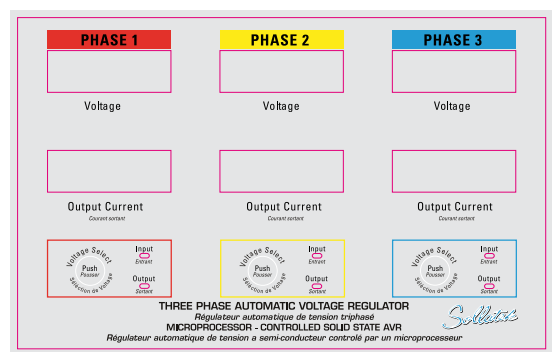

Front panel

TO CALCULATE THE VA:

$$VA = \text{Single phase amps} \times \text{single phase voltage} \times 3$$

i.e: 20 (amps) x 230 (voltage) x 3 = 13800VA

TO CONVERT TO kVA:

Divide the VA by 1000:

i.e: 13800 x 1000 = 13.8kVA

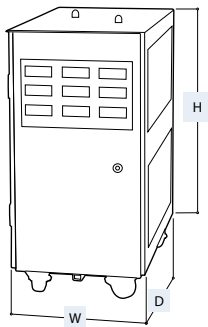

SPECIFICATIONS

Model	Amps per phase	Voltage	KVA	Weight kg	Dims (mm) W x D x H
AVR3x20-22	20	230/400	13.8	100	450 x 635 x 850
AVR3x30-22	30	230/400	20.7	150	450 x 635 x 850
AVR3x50-22	50	230/400	34.5	210	500 x 685 x 1060
AVR3x75-22	75	230/400	51.7	285	600 x 735 x 1110
AVR3x100-22	100	230/400	69.0	400	500 x 835 x 1280
AVR3x150-22	150	230/400	103.5	450	500 x 835 x 1280
AVR3x250-22	250	230/400	172.5	675	680 x 1200 x 1990
AVR3x300-22	300	230/400	207.0	735	680 x 1200 x 1990
AVR3x400-22	400	230/400	276.0	790	680 x 1200 x 1990
AVR3x700-22	700	230/400	483.0	1500	1360 x 1200 x 1990
AVR3x800-22	800	230/400	552.0	1590	1360 x 1200 x 1990
AVR3x900-22	900	230/400	621.0	1700	1360 x 1200 x 1990
AVR3x1000-22	1000	230/400	690.0	1850	1360 x 1200 x 1990
AVR3x20-11	20	115/200	6.9	75	350 x 635 x 744
AVR3x30-11	30	115/200	10.3	100	350 x 635 x 744
AVR3x50-11	50	115/200	17.25	165	350 x 686 x 1009
AVR3x75-11	75	115/200	25.87	190	350 x 686 x 1009
AVR3x100-11	100	115/200	34.5	210	500 x 835 x 1280
AVR3x150-11	150	115/200	51.75	285	500 x 835 x 1280
AVR3x250-11	250	115/200	82.62	425	680 x 1200 x 1990
AVR3x300-11	300	115/200	103.5	460	680 x 1200 x 1990
AVR3x400-11	400	115/200	138.0	510	680 x 1200 x 1990
AVR3x700-11	700	115/200	241.5	1500	1360 x 1200 x 1990

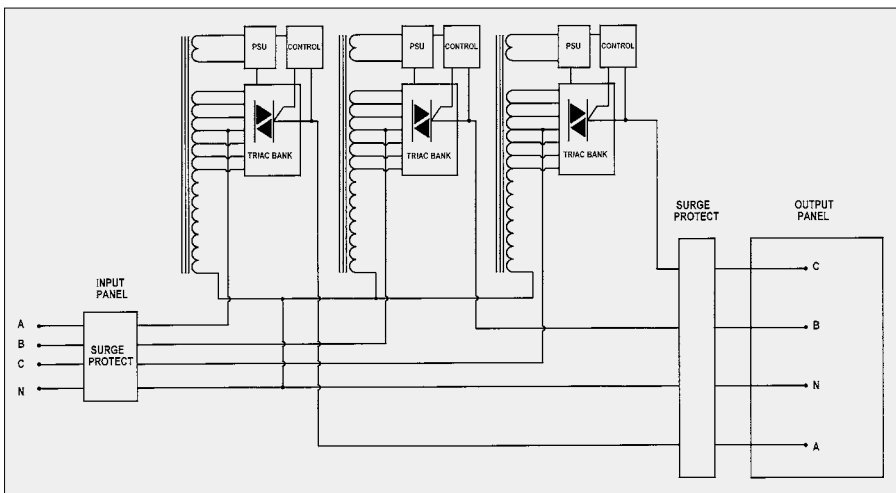

Block diagram of Sollatek Three Phase AVR

All the above are standard models. Input range for the standard models is -30% to +22%. Other models can be made to order.

To reduce cost and in areas of more stable input voltage, Sollatek can provide the M (AVRM) series with an input of +/-15%. The model number will be as above but with an M suffix. E.g. AVRM3x20-22.

For costs, dimensions and weights please apply to Sollatek.

AVR Three Phase Including Isolating Transformer

Main Features and Specifications

Introduction

The Sollatek isolating AVR is a version of the standard Sollatek AVR. Designed specifically to provide the high level of protection required for telecommunication applications and for equipment that requires a higher level of surge, spike, & noise protection. Using an isolating transformer, the AVR provides a clean neutral and 10:1 attenuation ratio ensuring that noise on the output is significantly reduced relative to the input.

As the Sollatek isolating AVR requires no incoming neutral it is protected against 'loss of neutral' problems. These can occur when the neutral connection is lost, either by damage or through the neutral cable being stolen and can result in voltage imbalance and damage in non-isolating regulators.

These models as standard include various additional features that are normally provided as optional extras. These include a higher IP rating of 44 to allow outdoor installation. The standard inclusion of output circuit breaker, manual by pass and automatic voltage switcher function all make this unit the preferred choice for mission critical applications.

Features

- Designed for telecom applications.
- Designed for remote operation where a high degree of reliability is essential.
- Input delta/star isolating transformer.
- Weather-proof enclosure.
- Fully electronic with no moving parts for:
 - High reliability
 - Speed of operation
 - Immunity to dust and other environmental conditions



Internal view of an Outdoor Isolating AVR

Applications

- Satellite operators
- Infrastructure telecom companies
- Embassies worldwide for reliable electrification of their posts
- Medical systems for digital imaging, scanning and x-ray equipment
- Mobile phone operators
- Grid utility companies for voltage regulation to their sub-stations
- Various United Nations divisions including WHO, UNICEF and WFP

Equipped with

- Bypass switch transferring the load to the utility grid
- Low and high voltage protection
- Surge and lightning protection
- Output circuit breaker

Standard features include

- Wide input frequency tolerance between 45 to 75 Hz allowing unit to function correctly in areas of severe voltage disturbances
- High overload capability with up to 150% for 4 minutes
- Very low losses and minimal heat dissipation due to high efficiency design
- Easy access cabinet with lockable doors.

SPECIFICATIONS

Model	Dimensions (DxWxH) mm	Weight kg
Isolating AVR - INDOOR (-I)		
AVR3x12-22-I	700 x 930 x 1100	175
AVR3x20-22-I	700 x 930 x 1450	250
AVR3x30-22-I	700 x 930 x 1450	350
AVR3x50-22-I	700 x 930 x 1450	400
AVR3x75-22-I	700 x 930 x 1450	500
AVR3x100-22-I	900 x 1200 x 1750	650
AVR3x150-22-I	900 x 1200 x 1750	1000
Isolating AVR - OUTDOOR (-IO)		
AVR3x12-22-IO	1110 x 370 x 1090	150
AVR3x20-22-IO	1110 x 450 x 1190	230
AVR3x30-22-IO	1110 x 450 x 1190	325
AVR3x50-22-IO	1110 x 450 x 1190	375
AVR3x75-22-IO	1260 x 500 x 1200	475
AVR3x100-22-IO	1250 x 700 x 1300	620
AVR3x150-22-IO	1250 x 700 x 1300	950

AVR Three Phase OPTIONS

A NUMBER of options are available on the Sollatek 3 Phase AVR range;

1) Automatic Voltage Switcher option (AVS™) Option A

The AVS (a Sollatek UK Patent 2139436) option completes the protection that can be offered by the Sollatek AVR.

The AVS simply disconnects the mains when the voltage is 'BAD' and re-connects it automatically when the voltage returns to 'GOOD'. Using this principle, the AVS monitors the output of the AVR. If the AVR cannot correct the voltage sufficiently (in cases where the fluctuation is extremely high or extremely low), then the AVS will disconnect the output and thus provide this added protection to the appliance. When the AVR's output is acceptable, the AVS will monitor the supply for 1 minute to ensure stability and will then reconnect the mains.

The Sollatek AVS has an additional useful feature of Timesave™. Using its own microprocessor, the AVS will monitor the time. If the unit has been disconnected for more than 1 minute then the AVS will reconnect within 10 seconds.

2) Input/output circuit breakers Option B&C

Circuit breakers protect the load and the AVR from the harmful effects of overcurrent. It is recommended that all Sollatek AVRs are installed with at least input circuit breakers and, wherever possible, output circuit breakers. These can be provided by the customer or alternatively, for ease of installation and for compactness, they can be ordered as an option to be built in to the AVR.

3) RFI filter Option R

RFI interference can cause malfunctioning of equipment, loss of data and, in some cases, component failure. It can come from the supply side or from the load. If you think your site is potentially prone to RFI problems, please specify this option at the time of ordering. Sollatek engineers will advise regarding the correct RFI filter option.

4) Line reactor Option T

If harmonic interference is known to be present at your site, the line reactor option, connected at the input to the AVR, can be ordered to effectively filter out the unwanted harmonic content. For further details on harmonic pollution, please refer to the technical notes section on the inside back page.

5) Digital input/output voltage and current meters Option M

The Sollatek 3 Phase AVR can be ordered with meters to indicate the state of the input voltage to compare it with the output voltage. Current meters are useful to ensure that the load does not exceed the rating of the AVR.

6) Additional surge/spike suppression - The DSP option Option D&S

Extra surge/spike suppression is available on the Sollatek 3 Phase AVR range with the DSP. This will provide a high level of protection from lightning induced voltage and other voltage surges on the mains supply.

- Designed to handle surges of up to 20,000 amps
- Auto resetting
- Remote status indication via volt-free contacts
- Can be built-in or ordered separately in a plastic wall mounting enclosure
- Suitable for all current rating as the unit is shunt connected
- Peak surge current 20kVA
- Limiting voltage 750V
- Multiple discharge current 20 shots @ 10kA
- Filtered option attenuation 65dB @ 10 Mhz



DSP TECHNICAL SPECIFICATIONS

Maximum let through voltage (8/20 ms)	750V
Response time	10 ns
Peak discharge current	20kA*
Nominal voltage	380/415V
Total energy (DSP3P)	2560 J

* higher rating available up to 150kA

7) Manual by-pass switch Option Y

The function of the bypass switch option is to allow the user to remove a regulator from service whilst the load remains connected to mains power. This has the benefit of allowing safe access to the AVR for servicing without having to disconnect power from the load, thereby reducing system downtime.

8) Isolation transformer Option I

See page 10

9) Outdoor enclosure Option O

See page 10

10) Changeover switch Option P

Manual switch that will by pass the incoming mains from the AVR directly to the load. The AVR will remain powered on. To take the AVR off-line for maintenance, the system will need to be powered down first.

AVR OPERATION PRINCIPLE

AVR Function

This is based on an auto transformer with tap changing on the output. There are seven taps to each transformer giving an accurate output voltage for a wide range of input voltage. The taps are switched by generously rated Triac banks to cope with motor start loads.

This technique results in a voltage stabiliser which has no moving parts, responds quickly to voltage fluctuations and is not as large or heavy as other AVRs utilising different regulation techniques.

A micro-controller forms the heart of the control system. It measures the AVR output voltage and turns on the appropriate Triac bank to select the correct tap.

A potentiometer is provided for fine adjustment of the output voltage. The micro-controller also measures the frequency of the mains supply and compensates accordingly. This also means that the AVR will work automatically over a frequency range of 45 - 75Hz and down to as low as 30Hz for short periods to help cope with diesel generator loading problems.

Frequency and voltage measurements are filtered by the circuit and software to remove noise and so prevent spurious tap changes. In an industrial environment there can be a large amount of electrical noise and interference present on the mains and load cabling. This may be caused by other equipment in the building such as electric motors and speed controllers, contactors and relays, electric welding, etc. This will distort the waveform of the electricity. To avoid this, spike suppressors are fitted to the AVR input and output to clip any high voltage transients on the line. Additionally, a capacitor type filter is fitted to the measurement input to the AVR to further attenuate spikes and to filter out high frequency noise and interference. As a further precaution, the software programme in the micro performs mathematical filtering using various averaging techniques. The software does a number of checks to ensure that the measurements it is getting are reasonable and consistent. All of these aspects of the design result in an AVR which is rugged and will perform well in an industrial environment.

Zero-Voltage Switching

The AVR uses an auto transformer with tap changing to regulate the supply. The taps are selected using triacs which are controlled by a microcontroller. The micro measures the voltage of the mains wave-form many times every cycle so as to determine the voltage and decide which tap to select. The micro also uses these measurements to synchronise the running of its software program to the mains wave-form. When a tap change is necessary, the micro watches for the mains voltage to reach zero volts and then it turns off the present Triac and turns on the new Triac. The micro and the triacs are semiconductor devices and switch very fast so that there is no interruption in the supply. This means that the new Triac is now in operation, selecting the new tap, at the very start of the next half cycle of the mains wave-form. The AVR will continue with this tap selected until the measurements by the micro determine that another tap change is necessary.

Zero-Voltage Solid State Switching is also superior to Relay/Mechanical based switching as it avoids interruption to the supply and also superior to servo based switching which apart from slow response and requiring maintenance, produces noise as the motor brushes move during correction.

Spike Protection

The Sollatek AVR is protected against spike and surges primarily by large Metal Oxide Varistors fitted at the input to the unit (260 Joules - 350VAC). These are fitted between the three lines and neutral and between the three lines and earth. These have the combined function of protecting the AVR and the load.

There is also a further Metal Oxide Varistor (1.5Joule - 31VDC) on each circuit board to protect the AVR's low-voltage circuitry. Polyester capacitors are fitted to all power supplies within the unit to filter out interference.

AVR TECHNICAL NOTES

In most applications, purchasing a stabiliser is simply a process of deciding the power requirement and the voltage and choosing a suitably rated unit. However, ambient temperature, altitude, load duty cycle, type of load are also all important factors in deciding which AVR to buy. Furthermore, in certain situations it can be necessary to consider in greater detail the characteristics of the electricity supply and connected load when selecting an AVR. Please see the notes below for further details:

Ambient Temperature. Ambient temperatures in excess of 40°C should be mentioned at the time of ordering as AVR size or rating may be affected. As a rule of thumb, output power should be de-rated by 10% - 15% per 10°C above 40°C ambient.

Supply Frequency. The Sollatek standard ranges of AVRs are suitable for both 50Hz and 60Hz supplies. However, frequencies below 50Hz result in larger transformer and therefore AVR size, while frequencies above 50Hz may enable AVR size to be reduced. Any frequency other than 50Hz should be notified at the order/enquiry stage.

Duty Cycle. If the AVR is to be used continually for considerably less than 100% of the time, allowance can be made for this, leading to a reduction in transformer size. The effective power in VA may be estimated from the following formula:

$$\text{Effective VA} = \sqrt{\frac{\text{Time on (mins)} (I^2)}{\text{Total Time (mins)}}} \times \text{Volts} \times 3$$

Time on = time in minutes that AVR supplies current (say 15 minutes)

Total time = total length in minutes of period in question (say 60 minutes)

I = Output current (say 20A)

In the above example, the AVR supplies 20 Amps for 15 minutes out of every 60 minutes. Duty cycle information may result in cost reduction and should be notified at the time of enquiry/order.

Operation at Altitude. The operation of electrical equipment at high altitude causes cooling by the circulation of air to be reduced. The greater the altitude the greater this effect. It is therefore important to indicate that the AVR is destined for a high altitude environment at the time of ordering. In this case, a high altitude is regarded as above 1500m.

Motor Starting. Motor loads draw a very high initial starting current from the AVR. Whilst the AVR is designed to be able to supply this initial high current without damage, repeated motor starts within a short period may cause excessive heating in the AVR. If motor based, air conditioner or refrigeration equipment are likely to constitute a large proportion of the AVR load, this should be indicated at the point of enquiry. Since this could result in an increase in AVR size, it may be beneficial in some instances to fit a soft start device to the motor to reduce starting surges. Please contact customer support at Sollatek UK or your nearest Sollatek agent for further advice.

Neutral. The Sollatek 3 phase AVRs MUST have a fully rated neutral connection to the supply.

Harmonics. It is important to state whether harmonics will be present on the supply, or will be generated by the load. Harmonics can be created by devices such as thyristors, silicon controlled rectifiers, switch mode power supplies, computer, UPS, television loads, fluorescent lamps with electronic ballasts, variable speed drives and welding equipment. Alternatively harmonics can be generated from the supply side by neighboring installations. If you think harmonics are present on the supply please contact customer support at Sollatek UK or your nearest Sollatek agent for further advice.

Circuit Breakers. As a minimum, the mains input to the AVR should be protected by a circuit breaker. For full protection an output circuit breaker should also be fitted. The input circuit breaker should be rated at 1.4 x output current. The output breaker should be rated at output current. The Sollatek AVR – single phase models – are all protected by either a fuse or circuit breaker. Circuit Breaker is an option on the three phase models.

Spike Protection. The AVR is protected against high voltage surges and spikes on input and output by metal oxide varistor based surge suppressors. Spikes can be caused by lightning, switching heavy reactive equipment such as industrial motors and transformers, arc welding and electrical grid switching. In areas of extremely high spike activity, additional protection may be necessary. Please contact customer support at Sollatek UK or your nearest Sollatek agent for further advice.

Cable selection. When selecting cable for the AVR input / out connections, one should bear in mind the input current may be up to 40% higher than the output current of the unit. The input neutral (4-Wire system) must be fitted and be fully rated. Voltage-drop should be kept as low as practicable.

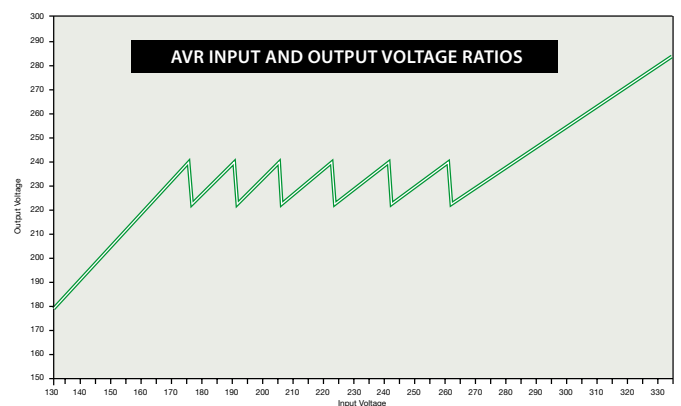

Sollatek worldwide companies and agents

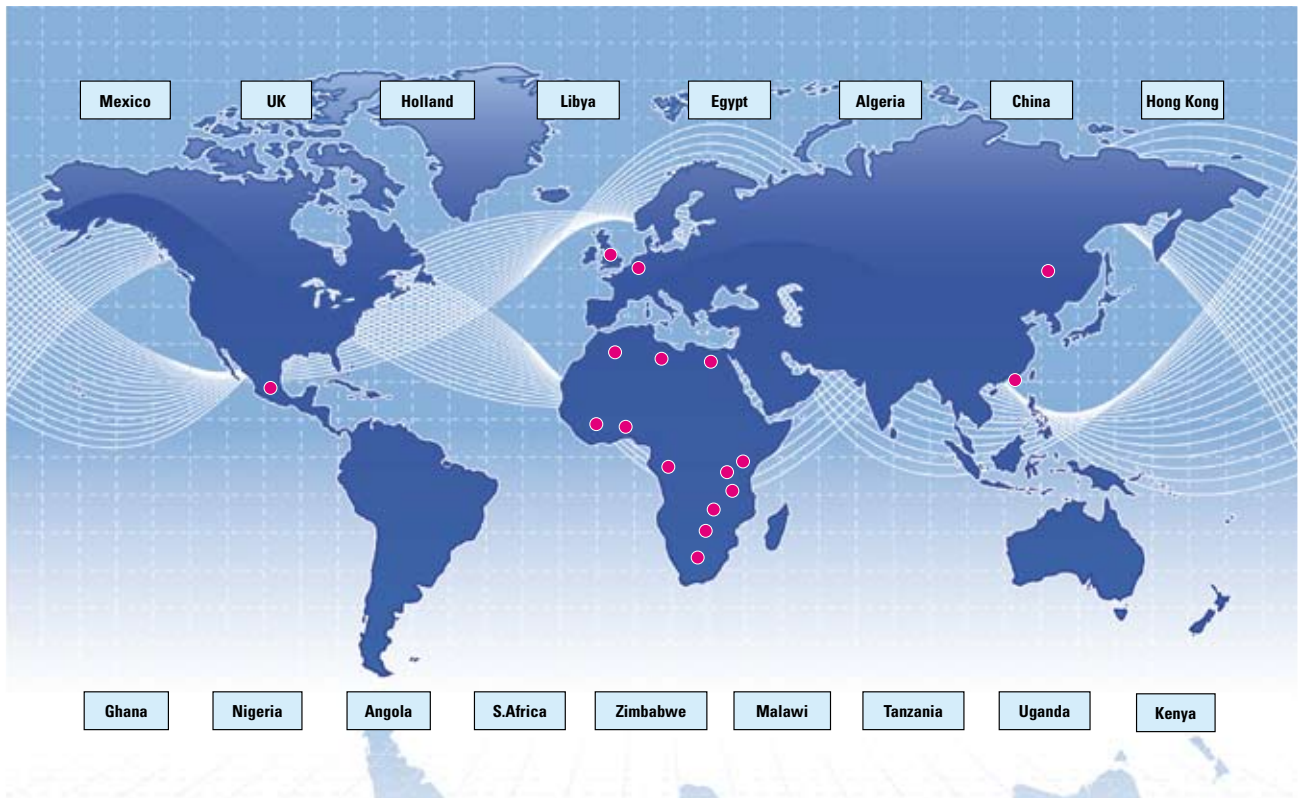

Distributors in over 50 countries including:

Algeria	Malawi	Zambia	Nepal	Yemen	United Kingdom
Angola	Mozambique	Zimbabwe	Pakistan	Australia	Mexico
Benin	Nigeria	Azerbaijan	Philippines	Denmark	USA
Cameroon	Sierra Leone	Croatia	Qatar	Finland	Venezuela
Egypt	South Africa	Hong Kong	Saudi Arabia	Greece	
Ghana	Sudan	Iraq	Taiwan	Holland	
Kenya	Tanzania	Jordan	Turkey	Norway	
Libya	Uganda	Kazakhstan	UAE	Sweden	

Sollatek (UK) Ltd
 Unit 10 Poyle 14
 Newlands drive,
 Poyle, Slough SL3 0DX,
 United Kingdom.

Tel:
 International: +44 1753 688300
 National: 01753 688300

Fax:
 International: +44 1753 685306
 National: 01753 685306

E-mail:
 sales@sollatek.com

Internet:
 www.sollatek.com

2 YEARS
WORLDWIDE
WARRANTY
 ON ALL SOLLATEK
 PRODUCTS

Sollatek provides you with full back up support and a two year worldwide warranty on all products, with local support in  over twenty countries worldwide.



www.sollatek.com



ISO9001: 2000 accredited company

All weights and dimensions are approximate. Specifications are subject to change without prior notice.

©Sollatek (UK) Limited 2007.
 All Rights Reserved.

SOLLATEK and the SOLLATEK device are the trade marks of the Sollatek group of companies.

Voltright AVR brochure April 08.
 Artwork ID: 10910006
 Stock number: 00026311